

Fig.1

A-A

Marking the holes with  $\phi 8\text{mm}$  and  $\phi 6\text{mm}$  drill bits.

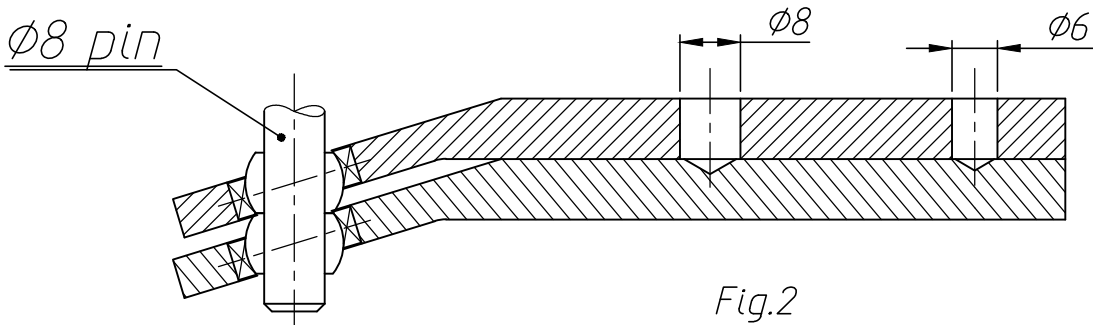

Fig.2

A-A

Drilling  $\phi 7.7\text{mm}$  and  $\phi 5.7\text{mm}$  holes.

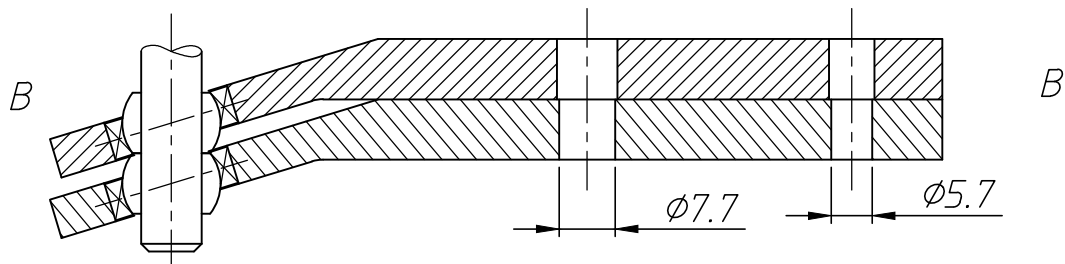

Fig.3

A-A

Reaming the holes with  $\phi 8\text{H9}$  and  $\phi 6\text{H9}$  reamers.

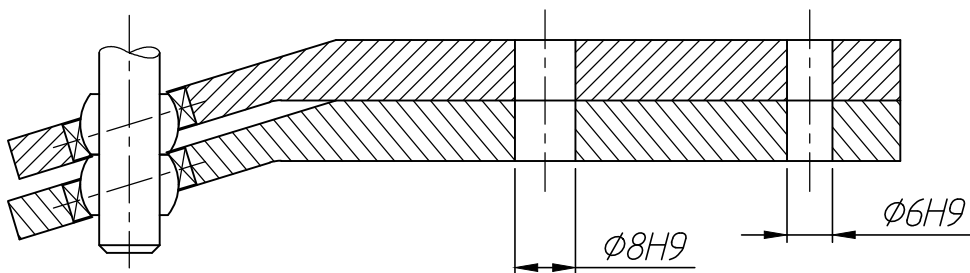

Fig.4