

**AEROPRAKT**  
**INFORMATION BULLETIN**  
**INSPECTION AND REINFORCEMENT OF THE**  
**MAIN LANDING GEAR BEAM OF A-22 AIRCRAFT**  
**IB A-22-04**

**MANDATORY**

**Repeating symbols:**

Please, pay attention to the following symbols throughout this document marking important information.

- ▲ **WARNING:** Identifies an instruction, which if not followed may cause serious injury or even death.
- **CAUTION:** Denotes an instruction, which if not followed, may cause severe damage.
- ◆ **NOTE:** Information useful for better handling.

**1) Planning information**

**1.1) Aircraft affected**

All versions of Aeroprakt-22 aircraft from №1 to №130

**1.2) Reason**

It has been found out, that the cracks in the landing gear beam and brackets (fig. 1) appear due to fatigue damage in the result of intensive aircraft operation on airfields with rough surface.

**1.3) Subject**

The landing gear beam, brackets

**1.4) Compliance**

Inspection of the main landing gear beam and brackets is to be carried out on the aircraft after 5000 landings.

**1.5) Approval**

The technical content of this Information Bulletin has been approved by Aeroprakt

**1.6) Manpower**

Estimated man-hours:

Retrofit work according to the section 3.1.1 can be performed within 5 or 6 hours, according to section 3.1.2 within 2 hours

**1.7) Mass data**

Change of weight - insignificant

**1.8) Other publications affected**

None

## 1.9) Spare parts

Spare parts are supplied upon request of aircraft owner.

## 2) Replacement part information

### 2.1) Replacement part – cost and availability

The reinforcement shapes and angles are supplied free of charge, excluding delivery

### 2.2) Special tooling / primer

For inspection beam and brackets: wrench set.

For repair: wrench set, drills: Ø3, Ø4.7, Ø6.2, reamer Ø5H7, powered drill, primer.

## 3) Accomplishment / Instructions

### 3.1) Instructions

Remove the landing gear legs (1), right and left brackets (2, see fig.1). Inspect the landing gear beam (3) and brackets for absence of cracks in the specified area. If any cracks are detected on the beam, perform the retrofit work according to section 3.1.1 (fig.2a, 2b). In case if cracks are detected on the brackets, perform retrofit work according to section 3.1.2 (fig.3).

- ◆ **NOTE:** Both right and left side of the landing gear beam and brackets must be inspected, though only right LG leg is shown on the pictures.

#### 3.1.1) Reinforcement of the LG beam

*The work is carried out according to fig. 1, 2a, 2b*

- 1) Drill out and remove the rivets (14).
- 2) Remove the old shape (4).
- 3) Drill the ends of the cracks with Ø3 drill;
- 4) Install new reinforcement shape (5) inside the beam;
- 5) Mark with pencil positions of the M6 bolts through the holes in the beam and remove the shape.
- 6) Drill Ø6.2 holes in the shape at the marks.
- 7) Install the shape and bracket and fix them with M6 bolts (8, 9, 10).
- 8) Mark the holes for M5 bolts in the beam (fig. 2b).
- 9) Drill Ø4.7 holes and enlarge them with Ø5H7 reamer.
- 10) Install M5 bolts (11, 12, 14) with primer.

#### 3.1.2) Reinforcement of the bracket

*The work is carried out according to fig. 3*

- 1) Drill the ends of the cracks with Ø3 drill and weld the cracks.
- 2) Fit the reinforcement angles (6 and 7, fig.3) and weld them (use TIG welding) all along their perimeter.
- 3) Drill Ø6 holes in the reinforcement shapes through the holes in the bracket.
- 4) Attach the bracket to the main landing gear beam (install M6 bolts with primer).

#### 4) Appendix

The following drawings contain additional information

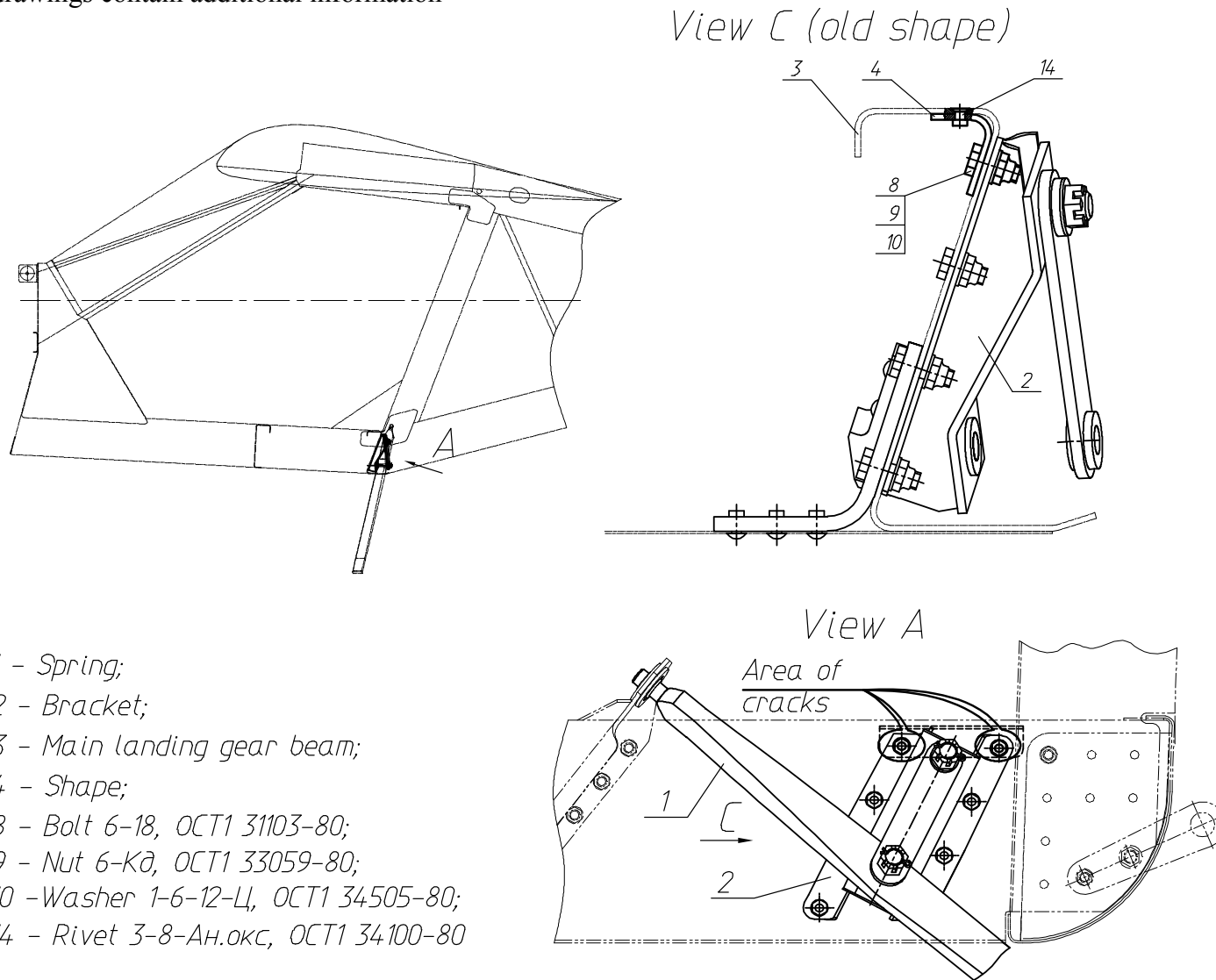

- 1 - Spring;
- 2 - Bracket;
- 3 - Main landing gear beam;
- 4 - Shape;
- 8 - Bolt 6-18, OCT1 31103-80;
- 9 - Nut 6-Kd, OCT1 33059-80;
- 10 - Washer 1-6-12-L, OCT1 34505-80;
- 14 - Rivet 3-8-AH.okc, OCT1 34100-80

Fig. 1

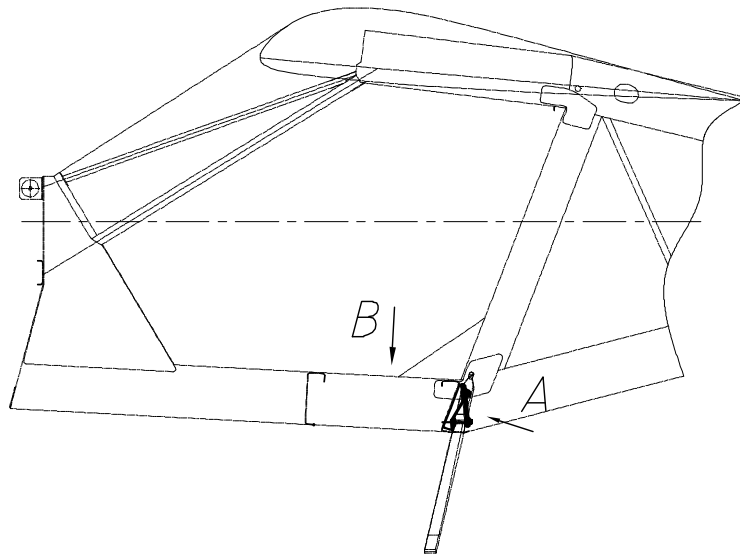

View A C (new shape)

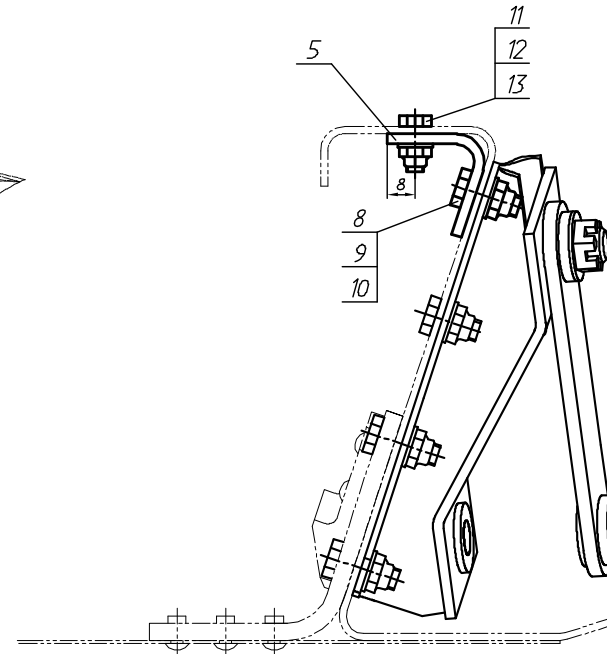

- 5 - New reinforcement shape;
- 11 - Bolt 5-6, OCT1 31103-80;
- 12 - Nut 5-Kø, OCT1 33059-80;
- 13 - Washer 1-5-10-L, OCT1 34505-80;

View A

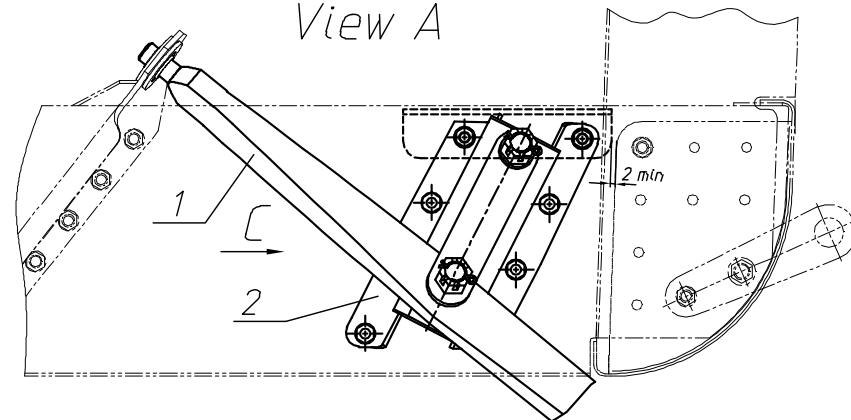

Fig. 2a

View B

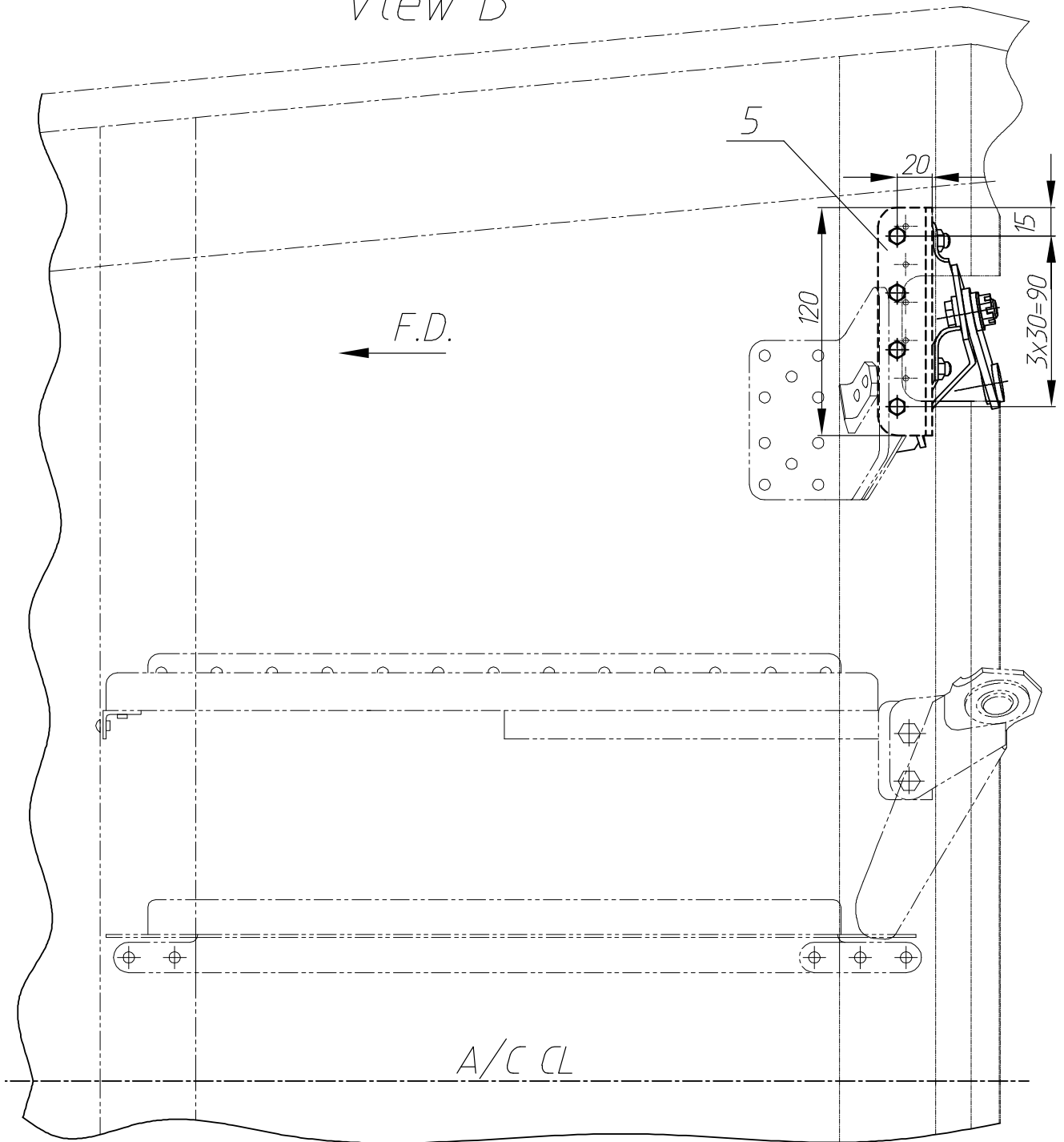

Fig. 2b

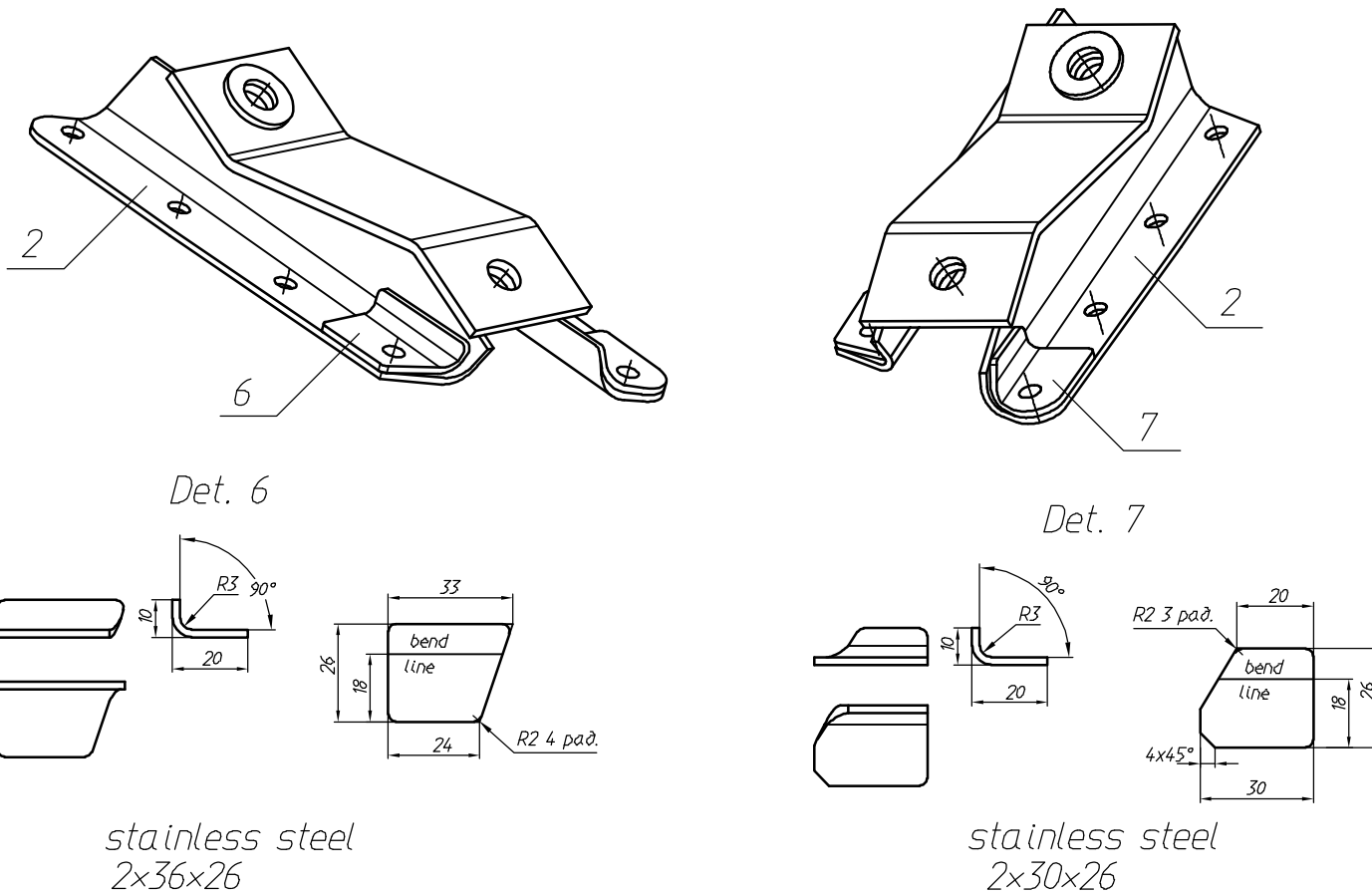

Fig. 3