

# MATCO mfg

## Wheels & Brakes

### General Information for Wheel & Brake Assemblies



Technical Service Guide

## Table of Contents

<u>SUBJECT</u>	<u>PAGE</u>
A. BRAKE LINING WEAR LIMITS-----	3
B. SWIFTLINE PAD REPLACEMENT-----	4
C. BRAKE DISK INSPECTION-----	5
D. Brake Lining Installation-----	7
E. Mounting the Tire & Tube-----	7
F. Tubeless Kit Installation-----	8
G. Wheel Assembly Instruction-----	10
H. Assembly Torque Values-----	12
I. Caliper Alignment-----	12
J. Bleeding the Brake System-----	14
K. Conditioning Procedures-----	17
L. Maximizing Brake Output -----	18
M. Lubricants-----	25
N. Technical Assistance-----	26
O. Nordlock washer Technical info-----	27

### DRAWINGS

Fig. 1 Wear Limit Indication Drawing-----	3
Fig. 2 Brake Disk Inspection-----	6
Fig. 3 Tubeless Mounting-----	9
Fig. 4 Caliper Alignment-----	13
Fig. 5 Pressure Bleeding-----	15
Fig. 6 Vacuum Bleeding-----	16
Dia. 1 Pedal Geometry-----	22
Dia. 2 Pedal Geometry -----	22
Dia. 3 Pedal Geometry -----	23
Dia. 4 Pivot Connect Geometry -----	23
Dia. 5 Heel Brake Geometry -----	24

## A. BRAKE LINING WEAR LIMITS

To eliminate the use of brake linings beyond their design limitation and reduce possible piston damage or fluid leakage, the following information is presented.

Matco linings should be replaced when the thickness of the remaining wear material reaches **0.100 IN. (2.54mm)** The **WHLM66-105, WHLLM66-106 and WHLM66-103A** linings have a visible wear notch located on the end of the lining.

The **WHLLM66-1052** wear notch is located at the top of the lining as noted in (Fig. 1). The inside edge of the notch indicates min-material condition.

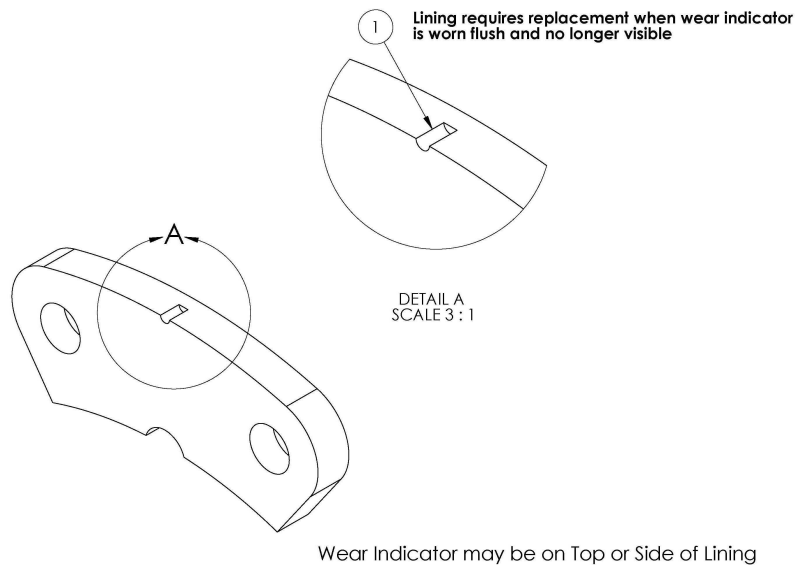

**Fig.1**

## B. SWIFTLINE PAD REPLACEMENT

### *SwiftLine* Pad Replacement Program

The *Swiftline* Pad Replacement program:

Simplifies pad replacement on MATCO mfg brakes  
And eliminates the need to rivet linings, saving you maintenance time and tooling costs.

The *Swiftline* program gives you a 20 % discount on all of our reline kits, saving you money.

Enrollment in the *Swiftline* pad replacement program entitles the brake owner to obtain the applicable brake reline kit at a 20% discount. In addition, replacement stationary and movable brake shoes are included at a 60% discount. The linings are riveted to the replacement brake shoes at the factory and sent ready to install.

Upon installation of the new components on the aircraft, the old stationary and movable brake shoes with worn out linings, may be sent to the factory and mounted with new linings, at the same 20% discount.

This second set of brake shoes with linings attached are returned to the aircraft owner and are ready for use when needed.

Two sets of brake shoes with factory installed linings, means always being prepared.

For more information on *Swiftline* call 801-335-0582

## C. BRAKE DISC INSPECTION

The MATCO brake disk should give years of trouble free service under normal field conditions. Conditions such as unimproved fields, standing water, industrial pollution, or frequent use of the aircraft may require more frequent inspection of the brake system including the disk in order to prolong the life of the brake linings.

The disk should be checked for wear (See **Fig. 2 Dim. "A"**) and for any grooves, deep scratches, excessive pitting or coning of the brake disk. Although coning is rarely a problem with the MATCO disk, if it should occur, coning beyond 0.015 inch (0.381mm) in either direction is cause for disk replacement.

Isolated grooves up to .030 inch (0.76mm) deep should not be cause for replacement. Any grooving of the disk however, will reduce the service life of the linings.

The Matco disk is normally plated for rust prevention. Within a few landings, the plating will wear off where the linings rub against the disk. The remaining portion of the disk will remain plated and corrosion free for an extended period of time under normal use. Nickel plated discs are available from MATCO for those demanding increased corrosion protection and wear.

Rust in varying degrees may form on the exposed portion of the disc. If a powdered rust appears on this surface, one or two braking applications during taxiing should wipe the disc clear. Rust build up beyond this point, may require removal of the disc from the wheel to properly clean both surfaces. A wire brush followed by 220-grit garnet paper should restore the braking surface adequately. Do not remove plating in areas that are not contacted by the linings.

**Fig. 2**

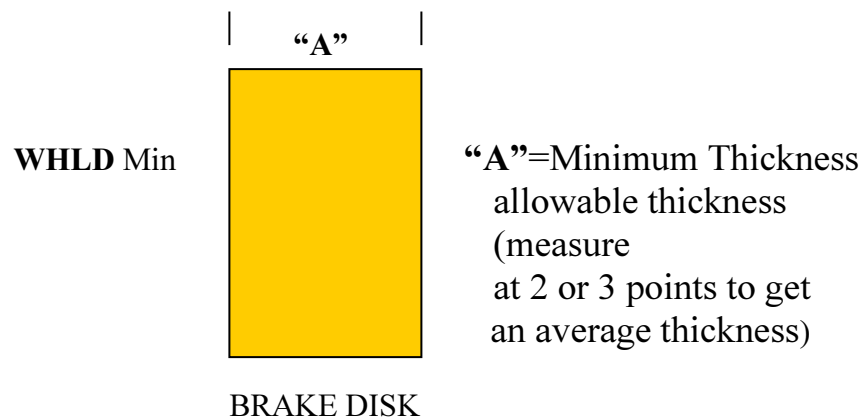

BRAKE DISK MINIMUM THICKNESS	
MATCO DISK	MIN "A" THICKNESS
WHL D4 (ALL)	.130"
WHL D5	.200"
WHL D5D	.325"
WHL D5ST	.325"
WHL D5LSA	.130"
WHL D6	.325"
WHL D6HE	.450"
WHL D164-017	.130"

## D. BRAKE LINING INSTALLATION

The following instructions offer a guide for properly removing and replacing Matco brake linings

1. Remove the caliper from the wheel
2. Remove old linings by drilling the crimped side of the rivet (Do not use a punch & hammer). Using a #25 drill (0.1495 diameter), drill through rivet taking care to avoid damaging the rivet hole. After drilling crimped edge off rivets, lift old lining and remaining rivet pieces from the brake shoe.
3. Inspect the brake shoe for any bending or other damage that may have occurred during service. A shoe with more than 0.010 bend should be replaced. Inspect rivet holes to ensure that no damage has occurred during removal.
4. Using a brake relining tool (*MATCO recommends a Threaded Screw Action such as the W404 from Aircraft Tool Supply Co.*) or pneumatic press, replace the lining using the brass rivets shown on the illustrated parts list.

## E. MOUNTING THE TIRE & TUBE

Care should be taken to avoid pinching the tube between the wheel halves when mounting the tire and tube. To avoid this, slightly inflate tube after placing it in the tire. Tire mounting soap may also help. A thin strip of cardboard or poster paper wrapped around the wheel between the mounting half and the tube will help in preventing the tube from being pinched during assembly if it is unusually tight. Another method is to use 3 ratcheting bar clamps evenly spaced around the tire and tube to compress the tire. Compress sufficiently to allow the wheel halves to be seated against each other at the shiplap without contacting the tire. The tube can be visibly inspected.

## F. TUBELESS KIT INSTALLATION

(on MH Series Wheels)

1. Inspect the rim face at the radius where the o-ring will seat, for deep scratches, nicks or imperfections. Smooth out any imperfections with a medium grit emery cloth. (**Fig. 3**)
2. Insert valve stem into the ½” hole and pull through from the inside of the rim. A rubber lubricant or soap and water solution may make it easier to install.
3. Take the brake half rim (*the one without the valve stem hole*) and insert it through the tire opening that will face towards the landing gear. Push the large o-ring over the diameter of the rim inside the tire and roll it back approximately 1 inch from the mating surface of the rim. Insert the other rim (*with the valve stem*) in what will be the outside of the tire assembly. Bolt the rims together with the three 5/16-18x.875 socket head cap screws, washers and nuts supplied spaced in every other hole.
4. Roll the o-ring to the center of the rim assembly. This is done by pushing the tire bead down evenly on the brake half side until it reaches the mating point of the two rim halves. The o-ring will seal the joint against leaks.
5. Coat the bead mounting areas of the tire and rim with suitable lubricant and inflate the tire to specification.
6. Install the remaining 5/16-18 nuts and washers on hub bolts and install the hub.

**Fig. 3**

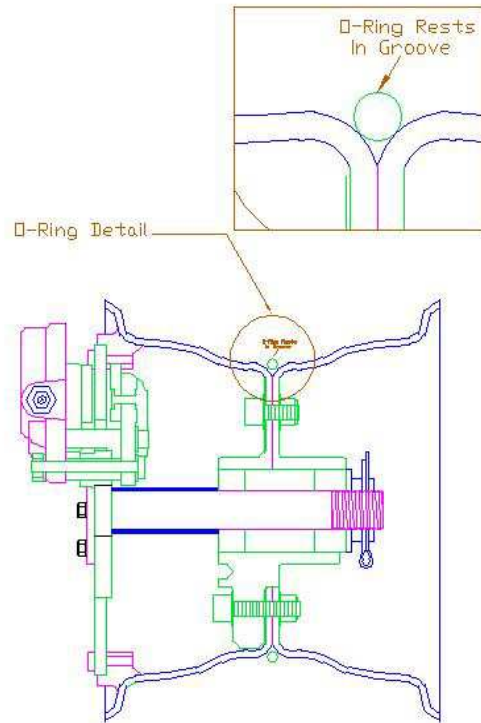

## **G. WHEEL ASSEMBLY INSTRUCTION**

### ASSEMBLY INSTRUCTIONS FOR MATCO WHEELS:

#### AXLE NUT TORQUE ON WHEELS WITH TAPERED ROLLER BEARINGS

If your wheel has *Tapered Roller Bearings*, the bearings two piece and are equipped with integrated grease seals on the bearing cone to ensure the longest possible bearing life. This is a two piece bearing with the race pressed in to the wheel and the cone with roller separately removable. The torque procedure for bearings with this type of seal is different than for tapered roller bearings without them.

A common torque technique for bearings without seals is to tighten the axle nut until the wheel stops spinning freely and then back off to the nearest locking feature.

#### THIS TECHNIQUE WILL NOT WORK ON BEARINGS WITH AN INTEGRATED GREASE SEAL

- . The reason for the different torque technique, is that the grease seal produces some drag and makes the wheel feel somewhat stiff when rotated. Reducing the axle nut torque until the wheel spins freely will allow the grease seal and the bearing cone to improperly rotate with the wheel.

NOTE: (the cone must not rotate relative to the axle).

The higher rolling drag is completely normal for this bearing and allows for longer bearing life since the seal will keep most contaminants out of the bearing.

Timken specifications state, for example, that the two 1.25 inch tapered roller bearings used on a Matco WE51 will produce between 18-26 inch pounds of torque (drag) when properly installed. A light coating of grease on the seal will help reduce the drag on initial installation. The drag will also reduce after the bearings have been installed, and the seal relaxes in the bore. **It is important that the axle torque be sufficient to keep the seal from rotating with the wheel.**

All o-rings in the brake and master cylinder, are Buna Nitrile and are **NOT** compatible with automotive glycol based brake fluids such as DOT 3, DOT 4, and DOT 5.1

**NOTE** USE ONLY red aircraft fluid (Mil-H-5606) brake Fluid or its equivalent.

The ideal mounting position for the brake caliper is the trailing side of the wheel with inlet and bleeder in a vertical axis. However, the caliper may be mounted at any location as long as the system can be bled of air properly.

When using MATCO mfg. flanged axles, they can be shimmed for toe-in or toe-out conditions, and spaced out from the wheel if necessary for the brake disk attachment screws to clear the landing gear leg. MATCO mfg. steel axle material is heat treated and cannot be welded.

## H. ASSEMBLY TORQUE VALUES

<b>TORQUE VALUES</b>	
PART NUMBER	TORQ / IN LBS
MSC10-24X.62BHCS	80 IN Lbs
MSC10-24X1.75SHCS	50 IN Lbs
MSC10-24NYLOCK	50 IN Lbs
MSC.25-20X1.75HH	99 IN Lbs
MSC.25-20X1.25SHCS	99 IN Lbs
MSC.25-20X1.5HH	99 IN Lbs
MSC.25-28NYLOCK	99 IN Lbs
MSC.31-18NYLOCK	120 IN Lbs
MSC.31-18X1.25SHCS	120 IN Lbs
MSC.31-18NYLOCK	120 IN Lbs
MSCAN4-17A	99 IN Lbs

## I. CALIPER ALIGNMENT

Caliper alignment is determined by measuring the maximum exposed spacer length, as measured on a new set of linings. (See **Fig. 4**)

1. Maximum exposed length should be 0.125 inches.
2. Minimum exposed length should be 0.05 inches
3. Adjust the length by moving the plate inboard or outboard as needed to reach proper measurement.
4. Note that this measurement applies to both single and dual piston calipers

**Fig. 4**

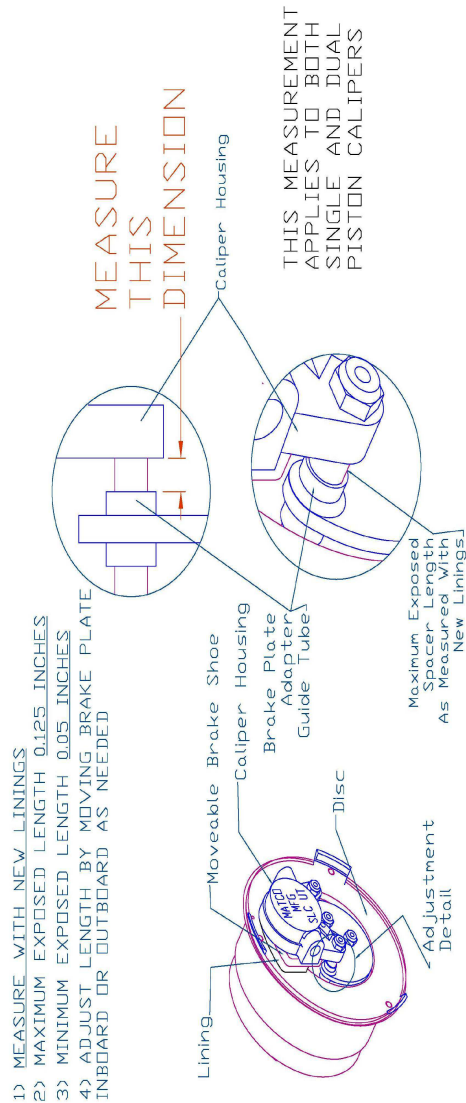

## J. BLEEDING THE BRAKE SYSTEM

1. Open brake bleeder valve slightly to facilitate the bleeding of air from the system.
2. Attach a tube from the nozzle of a squirt can of brake fluid, to the top of the brake bleeder valve. Pump the handle until oil flows bubble free from service hose before attaching.
3. Make sure that the master cylinder shaft is fully extended to open up the internal bypass valve.
4. Inject brake fluid (Mil-H-5606) or equivalent, into the puck housing and continue injecting until the fluid travels through the system in to the master cylinder.
5. Air in the system will be pushed up and out in to the master cylinder ONLY IF the master cylinder or remote reservoir is at the highest point in the system, and there are no loops in the brake lines.
6. Fluid should be pushed through the system until it reaches approximately  $\frac{1}{4}$  inch from the top of the master cylinder or remote reservoir
7. Close the brake bleeder valve, and remove the service hose.
8. GENTLY stroke each cylinder. If the brake system is free of air, the brake pedal should feel firm and not spongy. If not, repeat steps 1 through 7 until system is free of trapped air.
9. Fluid leakage from the top of the MCMC-5 / 5A master cylinder during operation indicates too high a fluid level.

**NOTE** The MCMC-5, 5A, 7 and 7S are NOT approved for inverted flight.

Fig. 6

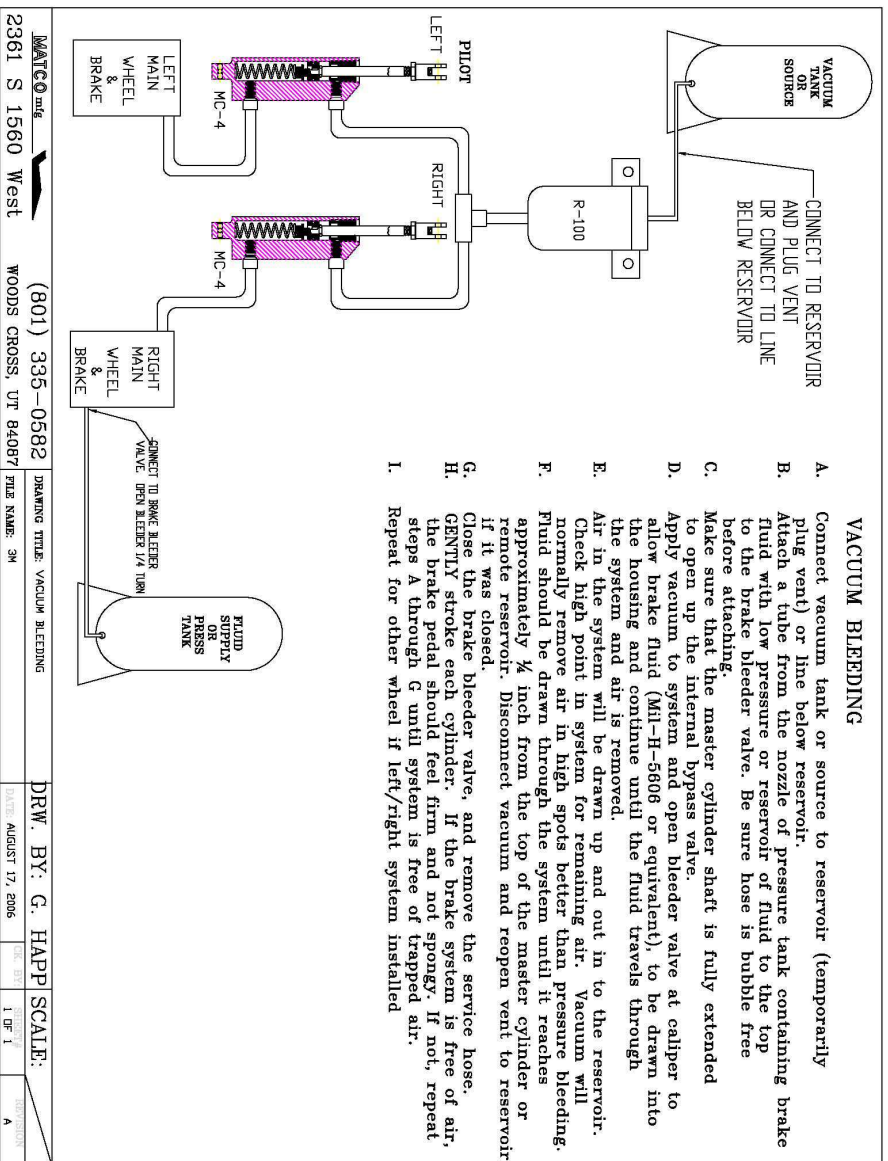
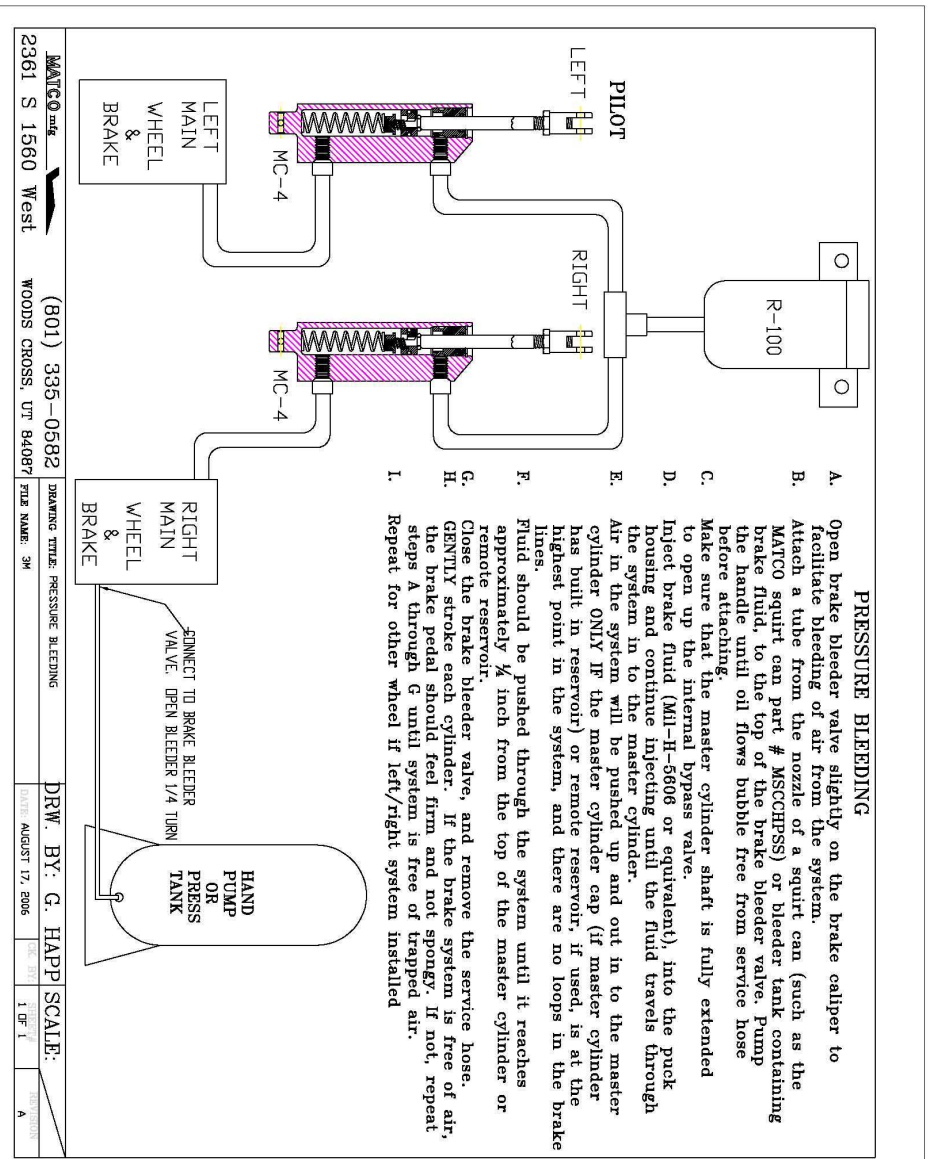

Fig. 5





## K. CONDITIONING PROCEDURES

**NOTE** It is important to condition the new linings after installation to obtain maximum service life and performance. The procedures below show when and how this should be done.

1. After the linings have been installed, apply brake pressure during high throttle static run-up. Note RPM at creep if any occurs.
2. Perform 2-3 high-speed taxi snubs to generate 300-400 degrees at brake pads and rotor by accelerating the aircraft to 30-40 mph. Remove power and apply firm braking pressure until slowed to 5 mph and release pressure. Do not bring aircraft to a complete stop during the taxi snubs. After accomplishing the snubs, do not drag the brakes. Allow the aircraft to roll as brake free as practicable until back to the tie down area. Avoid stopping the aircraft completely as much as practicable and park with brake pressure off.
3. Repeat step one and note RPM at creep if any occurs. There should be a noticeable increase in holding torque.
4. If properly conditioned, the pads will have a uniform shiny appearance (*glaze*) on the surface. Repeat steps 1-3 if necessary to produce glaze.

**NOTE** Forward movement of the aircraft during static runup could be caused by the wheels skidding and not brake malfunction. Use caution when braking heavy on aircraft with a tailwheel as it could cause the tail to lift from the ground.

Conditioning removes high spots, and creates a layer of glazed material at the lining surface. Normal braking will produce enough heat to maintain glazing during the life of the lining. Glazing can be worn off during light use such as taxiing.

## L. MAXIMIZING BRAKE OUTPUT

### *GETTING YOUR PEDAL GEOMETRY RIGHT*

#### BRAKE SPECIFICATIONS

All MATCO mfg. brakes have two specified ratings. The first is the energy rating which specifies the energy capacity of the brake. This value is used in selecting a brake that will be able to absorb the kinetic energy of the aircraft under the designers specified maximum energy condition (*generally maximum aircraft weight at a velocity above stall speed*). The energy rating is determined by the disc weight. Exceeding the energy capacity of a braking system leads to excessive disc temperatures. This can cause low friction coefficients and reduce brake torque and aircraft deceleration. Permanent damage to the disc can result in the form of warping or loss of corrosion protection.

#### BRAKE TORQUE

The second rating is for brake torque. The rated torque value is used to determine the deceleration and static torque for engine run-up that will be provided by the brake. A braking system using the same disc can have one energy rating and several torque ratings. This is possible by using different caliper configurations on the same disc. For example a braking system using a single caliper on a disc with a 189K ft-lb rating may have a torque rating of 1980 in-lb. The same braking system using two calipers would have the same energy rating of 189K ft-lb but would have a torque rating of 3960 in-lb. MATCO mfg. offers its customers a wide range of caliper configurations and disc sizes to allow for meeting both the energy and torque requirements of their aircraft.

## GETTING THE RATED TORQUE

The rated torque value assumes a nominally conditioned brake pad (*see pad conditioning procedures*), rated pressure applied to the brake, free floating calipers, and pad contact on both sides of the disc. Brake pad conditioning allows a glaze to form on the pads and provides the highest friction coefficient and drag force. MATCO mfg. Brake torque ratings are based on 450 psi applied pressure. Pressures below this value will generate proportionally lower torque. Pressures above this value will provide higher torque although pressures above 600 psi generally cause caliper deflections that reduce the torque increase. The torque rating assumes that all caliper force is used to squeeze the brake pads against the disc. If the caliper does not float freely, it is possible that only one side of the disc surface may be contacted resulting in 50% loss of torque.

## GET THE PRESSURE RIGHT

Assuming the calipers are properly mounted so that the pads make contact on both sides of the disc (both new and worn) and are maintained so that the calipers float freely, the most common reason for under performance of the brakes is low pressure. MATCO mfg. Brakes need 450 psi to achieve their rated torque. Additional calipers can be added to get higher torque at lower pressures, but is often more weight efficient to modify the hydraulic system pedal geometry to generate higher pressures. Systems using hand or foot operated master cylinders require a minimum of 2.5 to 1 mechanical advantage when using master cylinder, MC, like the MC-4 or MC-5 which have .625 inch diameter pistons. (*Systems using MC-4 or MC-5 with intensifiers have .500-inch pistons and require a 1.6 to 1 mechanical advantage*). Mechanical advantage, MA, is the ratio of the force applied to the master cylinder shaft divided by the force applied by the hand or foot. **Dia.1 page 20** shows two examples of pedal geometry.

The first has an MA of 1 to 1 since the distance from the applied load to the pivot point is the same as the distance to the MC and is undesirable. The second shows a more favorable configuration that will easily provide the required pressure to the brakes with moderate toe force. It is often necessary to keep the foot pedal shorter than that shown in **Dia.1**. An alternate geometry is shown in **Dia.2**. This design would utilize a fork arrangement on the MC connection to allow clearance of the MC body and then a short linkage to the MC connect point. A design common to many aircraft uses linkage as shown in **Dia.3**. This design also allows for a shorter brake pedal but has a major disadvantage. This linkage can be configured to have a proper MA in the start position (with the master cylinder fully extended). The MA varies with rotation however, as shown in **Fig.2 of Dia.3**, a 15 degree rotation of the linkage reduces the MA at the start position from 1.5 to 1 down to only 1.12 to 1. In actual operation, this has the effect of causing a nearly constant brake torque even though increasing force is applied. For example, if the geometry is set for an initial MA 2.5 to 1. In the start position and the pilot applies pedal force, the MC will begin to stroke as pressure builds. As the rotation occurs, the MA decreases. If there is any air in the brake lines or if there are long brake line runs, hydraulic system expansion will occur as pressure increases requiring more MC stroke. If the pilot applies more pedal force, more MC stroke occurs, and the MA decreases further. Even though the pilot has now increased his pedal force, the force applied to the MC will be only marginally increased because more rotation will result and cause a further decrease in MA. A geometry like that in **Dia.2** will provide the same reduced pedal height and is not prone to the effect of rotation since the MC is essentially connected to the brake pedal pivot. **Dia.4** illustrates the benefit of pivot connect geometry during rotation. The MA remains virtually unchanged for expected rotation angles and results in a linear pressure increase with applied pedal force.

## PEDAL GEOMETRY / POOR & MINIMUM

### Dia. 1 Figures 1 & 2

### HEEL BRAKES

A common means of providing pilots with differential braking ability without resorting to a more complicated geometry of toe brakes is to use heel brakes. The same design requirements exist for the MA of a system using heel brakes as for toe brakes. It is not uncommon to see MC's configured to allow the pilot to apply heel force directly to the MC by means of a pad or button connected on the end of the shaft. This configuration is shown in **Fig.1 of Dia.5. page 22** The MA of this system is 1 to 1 and produces very low pressure for reasonable heel force. Perhaps a larger concern however is the potential for causing damage to the MC. The MC is designed to accept loads applied along the length of the shaft. Loads applied off axis or perpendicular to the shaft cause bending moments in the MC shaft that it is not designed for. Damage to the MC end gland, or bending of the MC shaft may result if the off axis loads are high enough. A more desirable configuration for heel brakes is shown in **Fig.2 of Dia.5.** This system uses a short linkage connected to the MC that provides the 2.5 to 1 MA while insuring that loads will be applied along the length on the MC and prevent any damage during actuation.

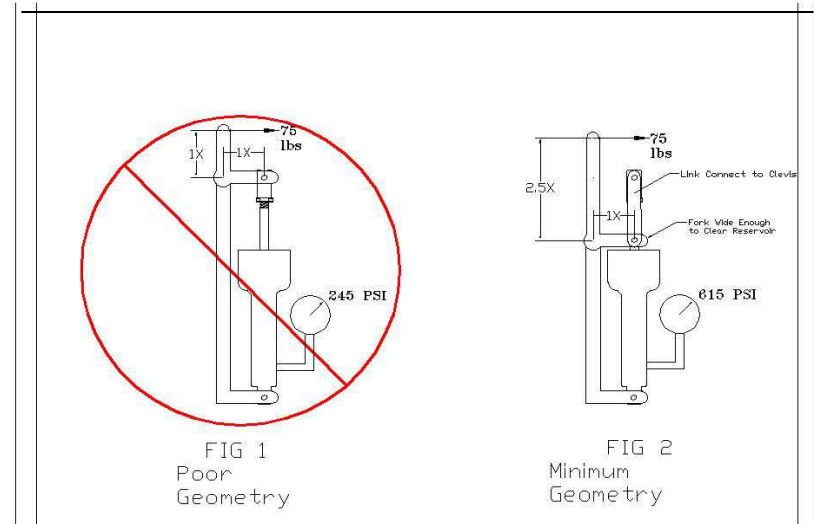

## PEDAL GEOMETRY / POOR & MINIMUM

### Dia. 2 Figures 1 & 2

### CONCLUSION

Like any system on an aircraft, the hydraulic system has many engineering options for providing the necessary requirements. The systems common on light aircraft must be engineered to provide adequate pressure to the brakes to achieve the rated torque.

**NOTE:** MATCO mfg. Brakes require **450 psi** to achieve their rated torque.

The pedal geometry whether hand, toe, or heel operated, requires a mechanical advantage of at least 2.5 to 1. This allows the pilot to easily generate the required 450-psi with moderate applied force. Pivot connected geometry provides the best means of accomplishing this requirement without the problem of rotational effect that reduces mechanical advantage.

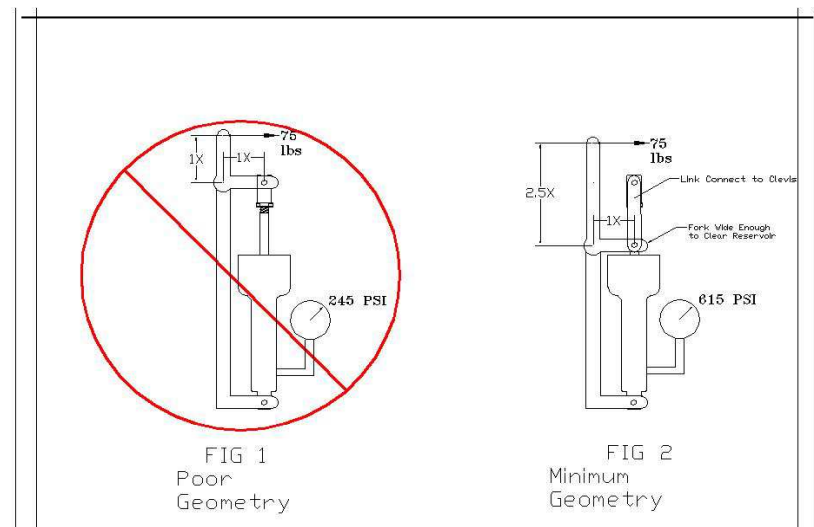

## PEDAL GEOMETRY / MECHANICAL ADVANTAGE

**Dia. 3 Figures 1 & 2**

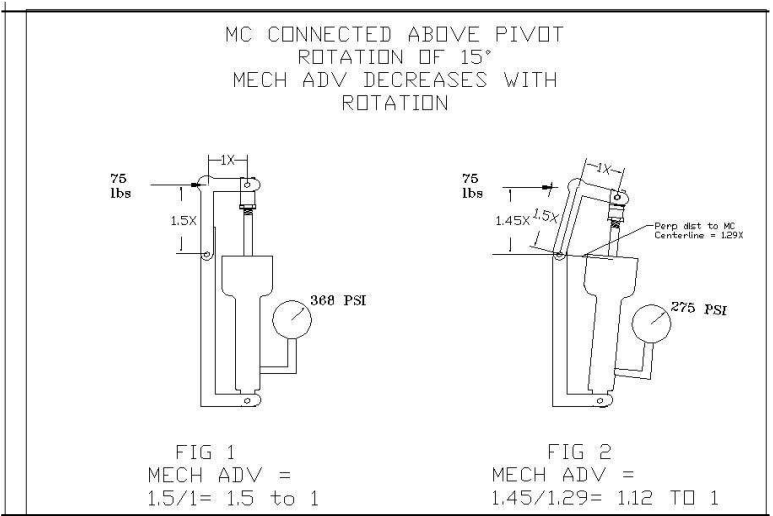

## PEDAL GEOMETRY / HEEL BRAKES

**Dia. 5 Figures 1 & 2**

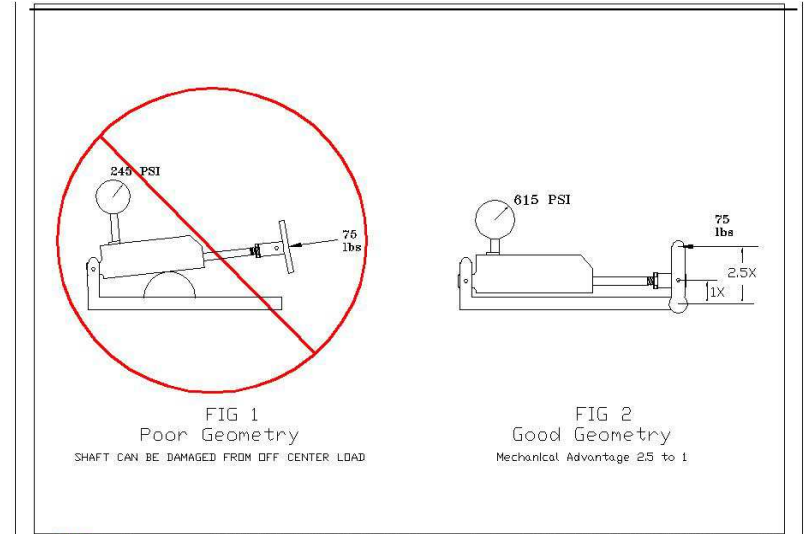

## PEDAL GEOMETRY / PIVOT CONNECT

**Dia. 4 Figures 1 & 2**

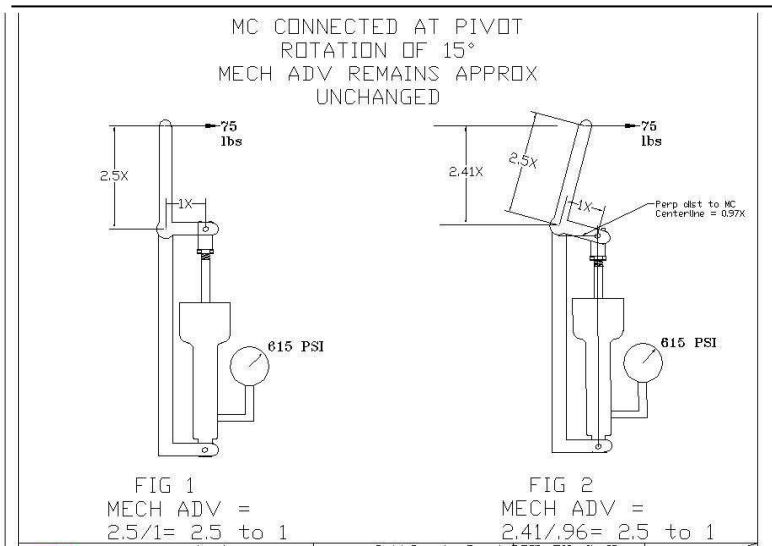

## **M. LUBRICANTS**

### **ELASTOMERIC COMPOUND LUBRICANTS**

HYDRAULICS: MIL-H-5606 / MIL-H-83282  
Or equivalent (Red Oils)

**NOTE** DOT 5.1 brake fluid is NOT compatible with MATCO mfg brakes, and will damage the Buna-N o-rings used in the system.

### **PETROLEUM LUBRICANTS**

WHEEL BEARINGS: MIL-G-81322  
MOBIL 28  
AEROSHELL 22  
MOBIL SHC-100  
Or equivalent lubricants

AMPHIBIOUS: HCF Grease P/N 605  
BG Products, Wichita, KS.

### **THREAD SEALANT**

TAPERED PIPE THREADS: Loctite 567 or equivalent

## **N. TECHNICAL ASSISTANCE**

For technical Information, Product Matching, and Helpful Hints, see our website at:

[www.matcomfg.com](http://www.matcomfg.com)

E-mail our technical service manager for specific information at:  
[tech@matcomfg.com](mailto:tech@matcomfg.com)

### **TECHNICAL ASSISTANCE**

To speak with someone in person about specific products or to find answers to technical questions, please contact us at our

**TECHNICAL HOTLINE**

**801-335-0582**

OR FAX US AT **801-335-0581**

### **Technical Support Disclaimer:**

While we at MATCO mfg. strive to ensure that the advice/information provided through our support is correct, MATCO mfg. does not accept any responsibility for errors or omissions. Any advice or information that MATCO mfg. gives you, via any form of communication is not a guarantee that it will correct your problem. It is only offered as assistance to you. MATCO mfg. will not be held responsible for any loss or damage as a result of our advice or information supplied.

## O. TECHNICAL ASSISTANCE

### NORD-LOCK Washers

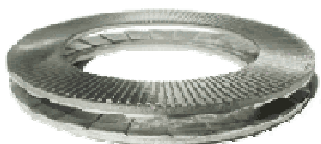

NORD-LOCK is a pair of washers with a wedge-locking action meeting DIN 25201 which is a unique method using tension instead of friction. The rise of the cams between the NORD-LOCK washers is greater than the pitch of the bolt. In addition, there are radial teeth on the opposite side. The washers are installed in pairs, cam face to cam face.

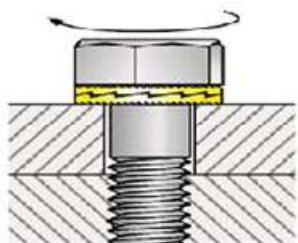

When the bolt and/or nut is tightened the teeth grip and seat the mating surfaces. The NORD-LOCK washer is locked in place, allowing movement only across the face of the cams. Any attempt from the bolt/nut to rotate loose is blocked by the wedge effect of the cams.

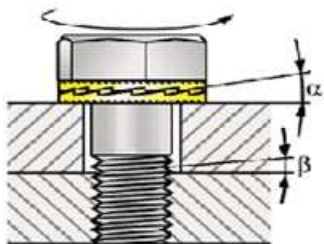

Here you see what happens when a bolt is untightened with a wrench. The pair of washers expand more than the corresponding pitch of the thread allows the bolt/nut to rise.

NORD-LOCK washers positively lock the fastener in a joint which is subjected to any kind of vibration or dynamic loads.

REPLACE the NORD-LOCK washers if the cam surface is worn and corners are rounded or if the pair does not seat cleanly against each other

## WHEEL INFORMATION SHEET

### OWNERS QUICK REFERENCE GUIDE

WHEEL MODEL # \_\_\_\_\_

BRAKE ASSEMBLY \_\_\_\_\_

BRAKE LININGS -----WHLLM66-\_\_\_\_\_

BRAKE FLUID-----MIL-H-5606 or Equivalent \_\_\_\_\_

BRAKE DISC-----WHLD \_\_\_\_\_

MIN DISC THICKNESS IS ----- Min \_\_\_\_\_

#### NORDLOCK TORQUE VALUES

MSCNL5 #10	80 in-lb	MSCNL1/4 1/4" Shoulder	100 in-lb
MSCNLX6 1/4" All-Thread	100 in-lb	MSCNL8 5/16"	120 in-lb

**Verify bolt bottoms against surface before installing NordLock**